

Ruud Ultra™ Series EcoNet® Enabled Two-Stage Variable Speed Multi- Position Gas Furnaces



U96V- Series

96% A.F.U.E.†

Input Rates from 40 to 115 kBtu
[11.72 to 33.71 kW]



†A.F.U.E. (Annual Fuel Utilization Efficiency) calculated in accordance with Department of Energy test procedures.



- 96% residential gas furnace CSA certified
- 4 way multi-poise design
- Two stages of operation to save energy and maintain optimal comfort level.
- Variable speed blower motor technology provides ultimate humidity control, quieter sound levels, and year round energy savings.
- The Ultra™ Series U96V is part of a new line of Ruud smart heating, cooling and water heating products. Using the latest in sensor technology and a powerful EcoNet® monitoring system, Ruud provides homeowners with a new level of protection, control and energy savings. Ruud smart heating, cooling and water heating products will alert the homeowner if there is ever an issue via the EcoNet Smart Thermostat¹ and the EcoNet Mobile app. The EcoNet Mobile App makes it easy for homeowners to manage their comfort environment at home or on-the-go*, while enjoying the convenience and savings benefits of a highly efficient system.
- PlusOne™ Diagnostics 7-Segment LED all units
- PlusOne™ Ignition System – DSI for reliability and longevity
- PlusOne™ Water Management System with patented Blocked Drain Sensor
- Heat exchanger is removable for improved serviceability. Aluminized steel primary and stainless steel secondary construction provide maximum corrosion resistance and thermal fatigue reliability.
- Low profile “34 inch” cabinet ideal for space constrained installations.
- Blower Shelf design – serviceable in all furnace orientations
- Pre marked hoses – insures proper system drainage
- Vent with 2" or 3" PVC
- Replaceable Collector box
- Hemmed edges on cabinet and doors
- Quarter turn fasteners for tool less access
- Integrated control boards feature dip switches for easy system set up
- Self priming condensate trap
- Solid bottom included
- Compatible with single or two stage thermostats. For optimal performance a two stage thermostat is recommended.
- Cabinet air leakage less than 2% at 1 inch H₂O when tested in accordance with ASHRAE standard 193

*WiFi broadband internet connection required. Download the EcoNet App from the App Store or Google Play to set up your EcoNet Smart Thermostat. Receipt of notifications depend on home WiFi set up. WiFi broadband internet connection required.

TABLE OF CONTENTS

Standard & Optional Equipment	3
Physical Data & Specifications	4
Model Number Identification	5
Dimensional Data.....	6
Blower Performance Data.....	7
Accessories	8-9
Limited Warranty	10

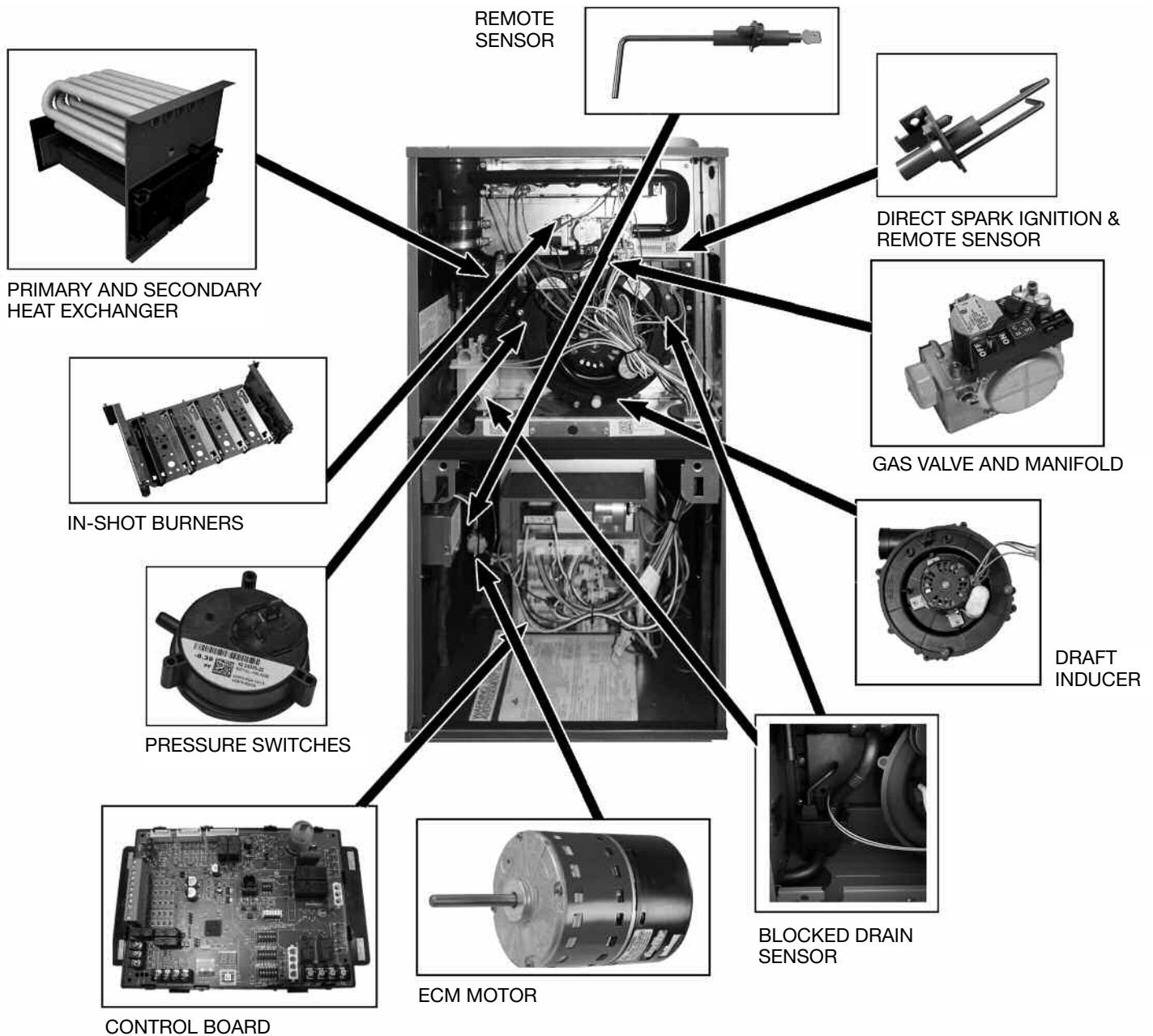

STANDARD EQUIPMENT

Completely assembled and wired; blocked drain sensor, 7 segment LED and marked hoses; heat exchanger; primary: aluminized steel, secondary: 29-4C stainless steel; 2 stage induced draft; pressure switches; redundant 2 stage main gas control; blower compartment door safety switch; solid state time on/off blower control; limit controls; manual shut-off valve; 100% safety lock out; cool fan off delay; field selectable heat fan off delay; one hour automatic retry; power and self-test diagnostics; flame sense current diagnostics; electronic air cleaner connections; humidifier connections; humidifier on/off delay; low speed continuous fan option; single speed option for heating and cooling applications; transformer; direct drive, variable speed electrically commutated blower motor (ECM). Solid bottom. (Please note: a thermostat is not included as standard equipment.)

OPTIONAL EQUIPMENT

Side and bottom filter racks; return air cabinet for all sizes.
NOTE: Furnace is not listed for use with fuels other than natural or L.P. (propane) gas.

All models can be converted by a qualified distributor or local service dealer to use L.P. (propane) gas without changing burners. Factory approved kits must be used to convert from natural to L.P. (propane) gas and may be ordered as optional accessories from a parts distributor.

For L.P. (propane) operation, refer to Conversion Kit Index Form.

WARNING
THIS FURNACE IS NOT APPROVED
OR RECOMMENDED
FOR USE IN MOBILE HOMES

Physical Data and Specifications—Upflow Models U.S. and Canadian Models

MODEL NUMBERS	U96VA 0402317MSA	U96VA 0602317MSA	U96VA 0702317MSA	U96VA 0702521MSA	U96VA 0852521MSB	U96VA 1002521MSA	U96VA 1152524MSA
HIGH FIRE INPUT BTU/HR [kW] ①	42,000 [12.31]	56,000 [16.41]	70,000 [20.50]	70,000 [20.50]	84,000 [24.61]	98,000 [28.72]	112,000 [32.82]
LOW FIRE INPUT	29,400 [8.61]	39,200 [11.49]	49,000 [14.36]	49,000 [14.36]	58,800 [17.23]	68,600 [20.11]	78,400 [23.00]
HEATING CAPACITY BTU/HR [kW]	41,000 [12.02]	55,000 [16.12]	68,000 [19.93]	68,000 [19.93]	82,000 [24.03]	95,000 [27.84]	109,000 [31.94]
HIGH ALTITUDE OUTPUT 10% DERATE [kW] ②	36,288 [10.64]	48,384 [14.18]	60,480 [17.72]	60,480 [17.72]	72,756 [21.27]	84,672 [24.81]	96,768 [28.36]
BLOWER (D x W) [mm]	11 x 7 [279 x 178]	11 x 8 [279 x 203]	11 x 8 [279 x 203]	11 x 10 [279 x 254]	11 x 10 [279 x 254]	11 x 10 [279 x 254]	11 x 11 [279 x 279]
MOTOR H.P. [W]— TYPE	1/2 [373] E.C.M.	1/2 [373] E.C.M.	1/2 [373] E.C.M.	3/4 [559] E.C.M.	3/4 [559] E.C.M.	3/4 [559] E.C.M.	3/4 [559] E.C.M.
MIN. CIRCUIT AMPACITY	8.00	7.00	9.00	12.00	12.00	12.00	12.00
MIN. OVERLOAD PROTECTION DEVICE	15.00	15.00	15.00	15.00	15.00	15.00	15.00
MAX. OVERLOAD PROTECTION DEVICE	15.00	15.00	15.00	20.00	20.00	20.00	15.00
MINIMUM EXT. STATIC PRESSURE (IN. W.C.) [kPa]	.18 [.045]	.20 [.050]	.23 [.057]	.23 [.057]	.28 [.070]	.28 [.070]	.28 [.070]
MAXIMUM EXT. STATIC PRESSURE (IN. W.C.) [kPa]	1.0 [0.249]	1.0 [0.249]	1.0 [0.249]	1.0 [0.249]	1.0 [0.249]	1.0 [0.249]	1.0 [0.249]
HEATING CFM @ MAX W.C. E.S.P. [L/s]	1250 [590]	1250 [590]	1190 [562]	1332 [629]	1850 [873]	1965 [927]	1700 [802]
FACTORY SETTING HEATING CFM [L/s]	950 [448]	1025 [484]	1015 [479]	1121 [529]	1470 [694]	1710 [807]	1450 [684]
COOLING CFM @ .5" [.124 kPa] W.C. E.S.P. [L/s]	1050 [496]	1050 [496]	1050 [496]	1750 [826]	1750 [826]	1750 [826]	1750 [826]
TEMPERATURE RISE-HIGH FIRE RANGE IN DEGREES °F [°C]	20 - 50 [11 - 28]	30 - 60 [17 - 33]	40 - 70 [22 - 39]	30 - 60 [17 - 33]	30 - 60 [17 - 33]	40 - 70 [22 - 39]	45 - 75 [25 - 42]
TEMPERATURE RISE-LOW FIRE RANGE IN DEGREES °F [°C]	15 - 45 [8 - 25]	20 - 50 [11 - 28]	30 - 60 [17 - 33]	20 - 50 [11 - 28]	20 - 50 [11 - 28]	30 - 60 [17 - 33]	35 - 63 [19 - 36]
APPROX. SHIPPING WEIGHT (LBS.) [kg]	128 [58]	128 [58]	132 [60]	139 [63]	147.5 [67]	152 [69]	165 [75]
AFUE ③	96.00%	96.00%	96.00%	96.00%	96.00%	96.00%	96.00%

NOTES: All models are 115V, 60HZ, 1 phase Gas connection size for all models is 1/2" [13 mm] N.P.T.

① Installation instructions for high altitude derate.

② Canadian installations only.

③ In accordance with D.O.E. test procedures.

*S=Standard Models

NOTE: Standard model complies with California low nox requirements.

This furnace does not meet air district requirements of 14 ng/J NOx emissions limit, and thus is subject to a mitigation fee of up to \$450. This furnace is not eligible for the Clean Air Furnace Rebate Program: www.CleanAirFurnaceRebate.com.

This furnace is to be installed for propane firing only in air districts requiring 14 ng/J NOx emission limits. Operating in natural gas mode is in violation of these Rules.

[] Designates Metric Conversions

Model Number Identification

<u>U</u>	<u>96</u>	<u>V</u>	<u>A</u>	<u>—</u>	<u>040</u>	<u>2</u>	<u>3</u>	<u>17</u>	<u>M</u>	<u>S</u>	<u>A</u>
Ruud	96% Efficient	Motor - ECM	Design Series A = 1st Design		Input BTU/HR	Stage - Two	Airflow 3 - Up to 3 Tons 5 - Up to 5 Tons	Cabinet Width 17 = 17.5" 21 = 21.0" 24 = 24.5"	Configuration - Multi-Position	S = Standard	Revision - Marketing (A - First Time Release) (B - First Revision)
					040 = 42,000 [12.31 kW] 060 = 56,000 [16.41 kW] 070 = 70,000 [20.51 kW] 085 = 84,000 [24.62 kW] 100 = 98,000 [28.72 kW] 115 = 112,000 [32.82 kW]						

[] Designates Metric Conversions

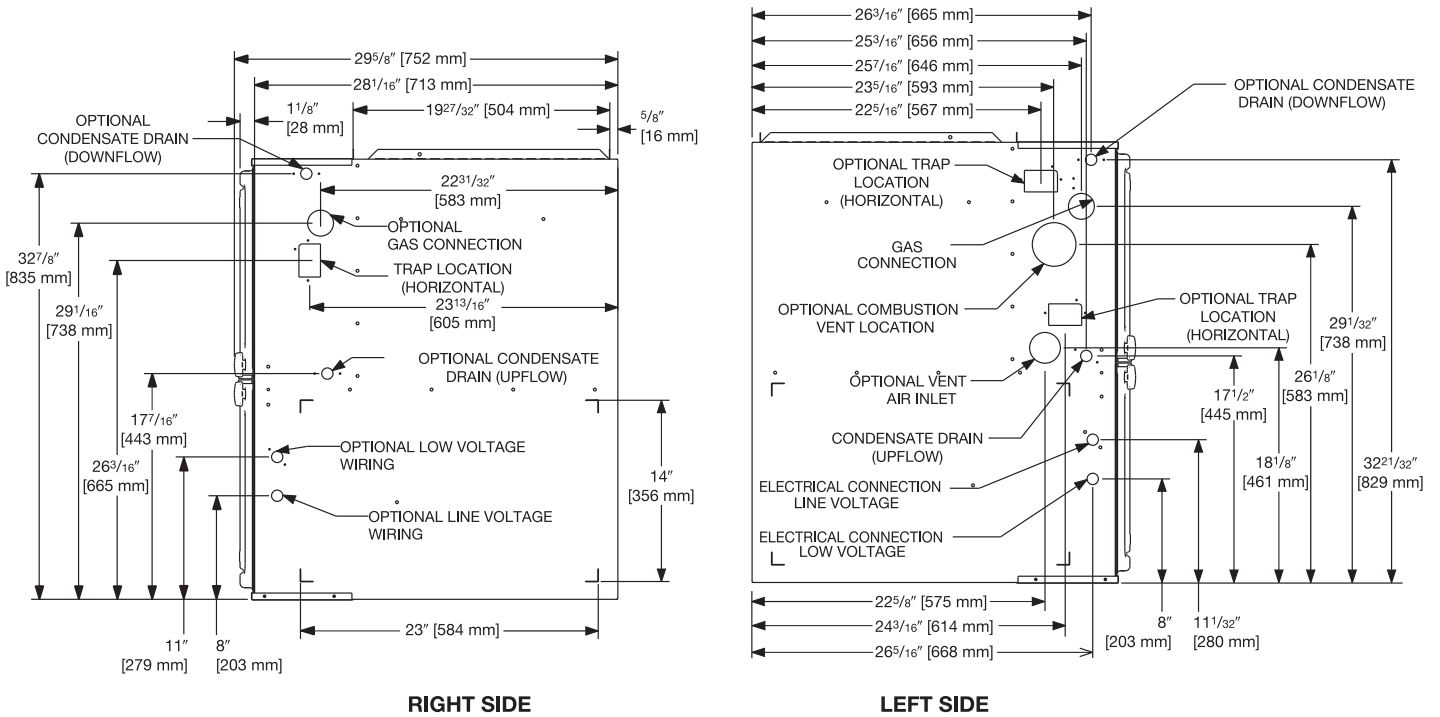
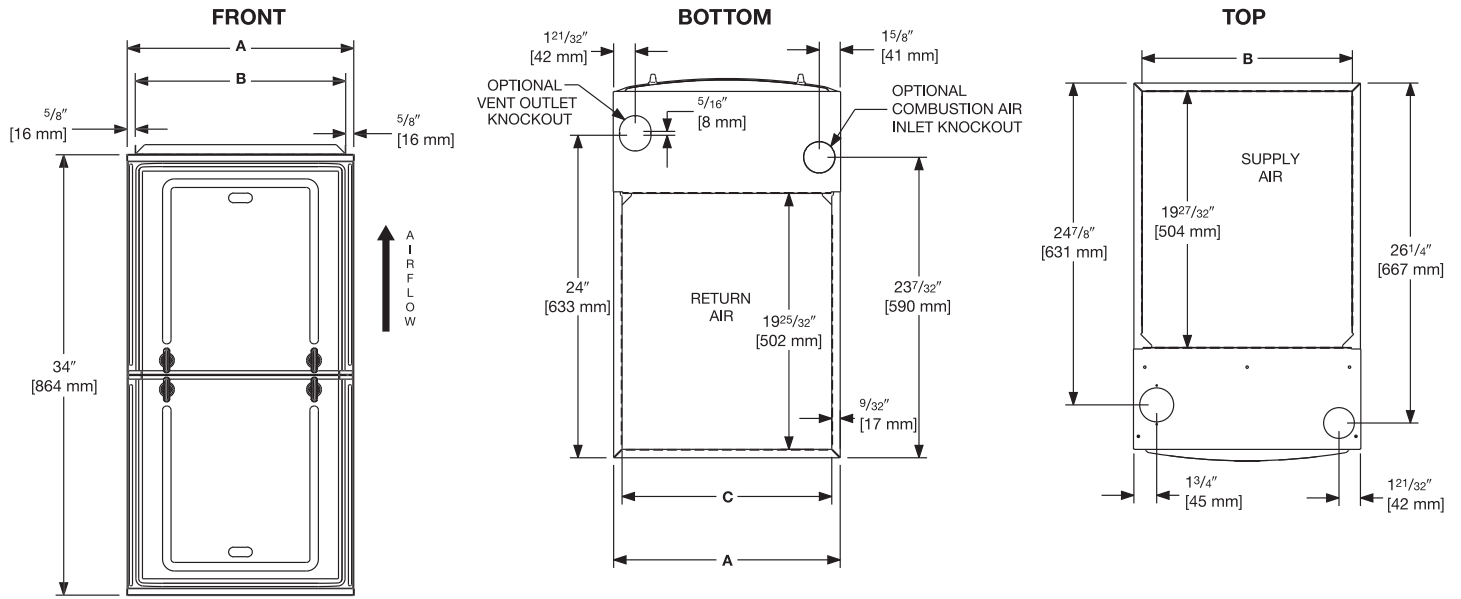

UNIT DIMENSIONS
(CLEARANCE TO COMBUSTIBLES)

MODEL U96V	LEFT SIDE	MINIMUM CLEARANCE (IN.) [mm]					SHIP WGTs.	FLANGE DIMENSIONS		
		RIGHT SIDE	BACK	TOP	FRONT	VENT		A	B	C
040	0	0	0	1 [25]	2 [51]	0	123.5 [56]	17 1/2 [445]	16 13/64 [413]	16 13/64 [412]
060	0	0	0	1 [25]	2 [51]	0	128 [58]	17 1/2 [445]	16 17/64 [413]	16 13/64 [412]
070	0	0	0	1 [25]	2 [51]	0	132 [60]	17 1/2 [445]	16 17/64 [413]	16 13/64 [412]
085	0	0	0	1 [25]	2 [51]	0	147.5 [67]	21 [533]	19 49/64 [502]	19 45/64 [500]
100	0	0	0	1 [25]	2 [51]	0	152 [69]	21 [533]	19 49/64 [502]	19 45/64 [500]
115	0	0	0	1 [25]	2 [51]	0	165 [75]	24 1/2 [662]	23 17/64 [591]	23 13/64 [589]

*A service clearance of at least 24" is recommended in front of all furnaces
 Supply and return depicted as upflow configuration.
 Flange configuration will vary depending on installation orientation.

[] Designates Metric Conversions

MODEL NUMBER			U96VA 0402317MSA	U96VA 0602317MSA	U96VA 0702317MSA	U96VA 0702521MSA	U96VA 0852521MSB	U96VA 1002521MSB	U96VA 115524MSB
TARGET GAS HEATING AIRFLOW	HIGH HEATING CFM [L/s]	SW 15 = OFF SW 16 = OFF	950 [448]	1025 [484]	1015 [479]	1121 [529]	1470 [694]	1710 [807]	1450 [684]
		SW 15 = ON SW 16 = OFF	825 [389]	880 [415]	950 [448]	973 [459]	1235 [583]	1490 [703]	1300 [614]
		SW 15 = OFF SW 16 = ON	1250 [590]	1250 [590]	1190 [562]	1332 [629]	1850 [873]	1965 [927]	1700 [802]
		SW 15 = ON SW 16 = ON	685 [323]	780 [368]	900 [425]	813 [384]	1120 [529]	1400 [661]	1225 [578]
	LOW HEATING CFM [L/s]	SW 13 = OFF SW 14 = OFF	790 [373]	925 [437]	900 [425]	1093 [516]	1300 [614]	1500 [708]	1250 [590]
		SW 13 = ON SW 14 = OFF	620 [293]	750 [354]	770 [363]	910 [429]	1065 [503]	1335 [630]	1060 [500]
		SW 13 = OFF SW 14 = ON	1000 [472]	1210 [571]	1050 [496]	1366 [645]	1775 [838]	1800 [850]	1400 [661]
		SW 13 = ON SW 14 = ON	550 [260]	660 [311]	700 [330]	813 [384]	925 [437]	1210 [571]	960 [453]
TARGET COOLING/ HEAT-PUMP AIRFLOW	HIGH COOLING CFM [L/s]	SW 4 = OFF SW 5 = OFF	1050 [496]	1050 [496]	1050 [496]	1750 [826]	1750 [826]	1750 [826]	1750 [826]
		SW 4 = ON SW 5 = OFF	875 [413]	875 [413]	875 [413]	1500 [708]	1400 [661]	1400 [661]	1400 [661]
		SW 4 = OFF SW 5 = ON	700 [330]	700 [330]	700 [330]	1300 [614]	1225 [578]	1225 [578]	1225 [578]
		SW 4 = ON SW 5 = ON	525 [248]	525 [248]	525 [248]	1125 [531]	1050 [496]	1050 [496]	1050 [496]
	LOW COOLING CFM [L/s]	SW 4 = OFF SW 5 = OFF	788 [372]	788 [371]	788 [371]	1313 [618]	1313 [618]	1313 [618]	1313 [618]
		SW 4 = ON SW 5 = OFF	656 [309]	656 [309]	656 [309]	1125 [530]	1050 [495]	1050 [495]	1050 [495]
		SW 4 = OFF SW 5 = ON	525 [247]	525 [247]	525 [247]	975 [459]	919 [433]	919 [433]	919 [433]
		SW 4 = ON SW 5 = ON	394 [186]	394 [186]	394 [186]	844 [398]	788 [371]	788 [371]	788 [371]

*S = Standard Models

NOTE Standard model complies with California low NOx requirements.

[] Designates Metric Conversions.

VENT TERMINATION KITS:

RXGY-E02: Vertical/Horizontal Concentric Vent Termination Kit 2" Pipe (US Only)

RXGY-E02A: Vertical/Horizontal Concentric Vent Termination Kit 2" Pipe (US & Canadian)

RXGY-E03: Vertical/Horizontal Concentric Vent Termination Kit 3" Pipe (US Only)

RXGY-E03A: Vertical/Horizontal Concentric Vent Termination Kit 3" Pipe (US & Canadian)

RXGY-G02: Direct Vent Furnace Side Wall Vent 2" or 3" (US Only)

RXGY-D05: Combustion Air Drain Kit 2"

RXGY-D06: Combustion Air Drain Kit 3"

NEUTRALIZER KIT: RXGY-A01
(Replacement Cartridge 54-22120-01)

EXTERNAL BOTTOM FILTER (UPFLOW/HORIZONTAL) RACK:
RXGF-CB

EXTERNAL SIDE (UPFLOW) FILTER RACK: RXGF-CD

EXTERNAL (DOWNFLOW) FILTER RACK: RXGF-CC

FILTER RACK FILTER SIZES* INCHES [mm]			
MODEL	RXGF-CB (UPFLOW/ HORIZONTAL)	RXGF-CD (UPFLOW)	RXGF-CC (DOWNFLOW)
U96VA040	15 ³ / ₄ x 25 [400 x 635]	15 ³ / ₄ x 25 [400 x 635]	12 x 20 [305 x 508]
U96VA060	15 ³ / ₄ x 25 [400 x 635]	15 ³ / ₄ x 25 [400 x 635]	12 x 20 [305 x 508]
U96VA070	15 ³ / ₄ x 25 [400 x 635]	15 ³ / ₄ x 25 [400 x 635]	12 x 20 [305 x 508]
U96VA070 (wide)	19 ¹ / ₄ x 25 [489 x 635]	15 ³ / ₄ x 25 [400 x 635]	12 x 20 [305 x 508]
U96VA085	19 ¹ / ₄ x 25 [489 x 635]	15 ³ / ₄ x 25 [400 x 635]	12 x 20 [305 x 508]
U96VA100	19 ¹ / ₄ x 25 [489 x 635]	15 ³ / ₄ x 25 [400 x 635]	12 x 20 [305 x 508]
U96VA115	22 ³ / ₄ x 25 [578 x 635]	15 ³ / ₄ x 25 [400 x 635]	14 x 20 [356 x 508]

*Filter racks are shipped without filters.
Filters shipped with furnace may be used or a suitable 1" [25.4 mm] filter.

[] Designates Metric Conversions

INDOOR COIL CASINGS

MODEL NUMBER
RXBC-D17A1
RXBC-D21A1
RXBC-D21B1
RXBC-D24A1

FOR HIGH ALTITUDES:

NOTE: For Canadian installations only, an optional derate (manifold gas pressure reduction) method may be used to adjust the furnace for altitude. See Installation Instructions for more information. This optional method may **NOT** be used for U.S. installations. See installation instructions as appropriate orifice change is required.

OPTIONAL HIGH ALTITUDE HEATING AIRFLOW ADJUSTMENT KITS			
KIT NUMBER	SEA LEVEL INPUT (BTU)	MINIMUM ELEVATION KIT RECOMMENDED	MAXIMUM ELEVATION KIT RECOMMENDED
RXGY-58	42000	6000	10000
RXGY-59	56000		
RXGY-60	70000		
RXGY-61	84000		
RXGY-62	98000		
RXGY-63	112000		

L.P. CONVERSION KIT: RXGJ-FP34

CONDENSATE PUMP KIT: PROSTOCK & 1PCB151TUL

DOWNFLOW/HORIZONTAL CONVERSION KIT: RXGY-CK

DOWNFLOW/HORIZONTAL LEFT ZERO CLEARANCE CONVERSION KIT: RXGY-ZK

COMBUSTIBLE FLOOR BASE: RXGC-B17
RXGC-B21
RXGC-B24



THE ECONET® SMART THERMOSTAT

BUILT-IN WIFI

4.3" LCD TOUCH SCREEN

LOCAL WEATHER – Current conditions plus 6-day forecast

5 OPERATING MODES – Heat, Cool, Auto, Emergency Heat and Fan Only

7-DAY PROGRAMMABLE SCHEDULE – Offers comfort without thought

ONE-TOUCH AWAY – Quickly switch to your energy-saving away preferences

VACATION SCHEDULING – Allows you to save while you're away and come home to comfort

MOTION SENSOR – Automatically wakes the screen as you approach

STANDBY SCREEN – Displays indoor temperature and current weather



UETST700SYS

OPERATIONAL FEATURES

AUTOMATIC CHANGEOVER – Transitions between heating and cooling automatically to keep the house comfortable

INTEGRATED WATER CONTROL – Enables easy water heater management

SMOOTH ARRIVAL – Prompts the system to start ahead of schedule to ensure the home is at the desired temperature at the scheduled time

HUMIDITY CONTROL – Supports humidifier accessories or over-cool based dehumidification

DETAILED OPERATING STATUS – View pertinent equipment status information and run times

CONTINUOUS FAN – Offers 5 speeds (Low, Medium Low, Medium, Medium High, High)

SHORT-CYCLE PROTECTION – Avoids damage to equipment from short run cycles

MONITORING & REMOTE CONTROL FEATURES

ACTIVE MONITORING – Alerts to problems that need immediate attention

REMOTE CONTROL – Allows adjusting of comfort and settings from anywhere using a mobile device

SERVICE ALERTS – Sends routine maintenance reminders

AIR FILTER MONITORING – Detects when it's time to replace the air filter

ALARM HISTORY – Displays time-stamped alarm codes with clear descriptions

ECONET SMART THERMOSTAT COMPATIBILITY

Models	Heating & Cooling									
	Gas Furnaces				Air Handlers		Air Conditioners		Heat Pumps	
	U802V	U96V	U97V	U98V	RHMV	RH2T	UA20	UA17*	UP20	UP17
UETST700SYS	✓	✓	✓	✓	✓	✓	✓	✓	✓	✓

**Models not EcoNet Enabled: RA1724AJ2NB, RA1736AJ2NB, RA1748AJ2NB, RA1760AJ2NB*

GENERAL TERMS OF LIMITED WARRANTY*

Ruud will furnish a replacement for any part of this product which fails in normal use and service within the applicable period stated, in accordance with the terms of the limited warranty.

***For complete details of the Limited and Conditional Warranties, including applicable terms and conditions, contact your local contractor or the Manufacturer for a copy of the product warranty certificate.**

Parts.....Ten (10) Years
Heat ExchangerLimited Lifetime
 Limited Lifetime
Conditional Unit Replacement
 (Registration Required)Ten (10) Years